



DNA-120-BF10-460W

Residential | Commercial

Our DNA Split Cell Series uses advanced selective emitter PERC technology with thin film layers to improve heat tolerance, maximize energy harvest, minimize resistive loss, and use 5% more of the available active area for optimal power performance.

Linear Performance Warranty

Industry Leading 30 Years Product and Performance Warranty

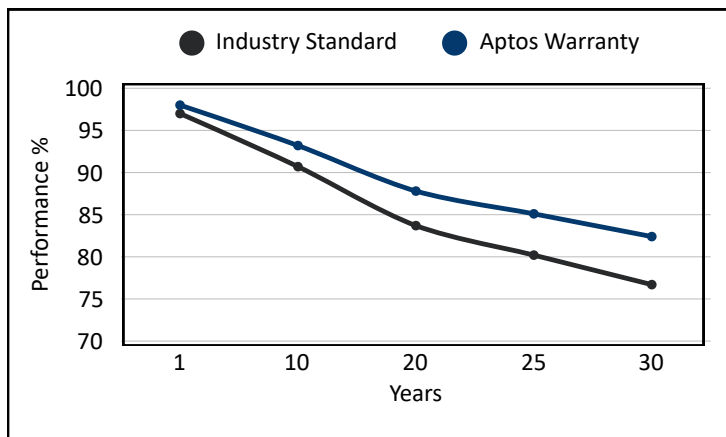

Key Features:

Advanced Technology

Patented DNA™ technology boosts power performance & module efficiency.

Miami-Dade Approved

Maximum Durability: LEVEL 6 SALT MIST Tested, 5400 Pa Wind Load Certified Panels

Bankable Investment

Comprehensive warranty that covers both 30-year product and 30-year power performance.

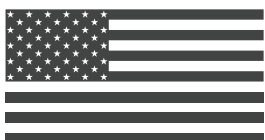

Designed and Engineered In Silicon Valley



Aesthetics

All black design with advanced split cell technology features 10 ultra-thin busbars that allow for less resistance and greater energy harvest.

Awards

Winners of the Leadership in Solar Energy award for three consecutive years and listed as one of the Top Solar Products from 2021-2022.

Certifications



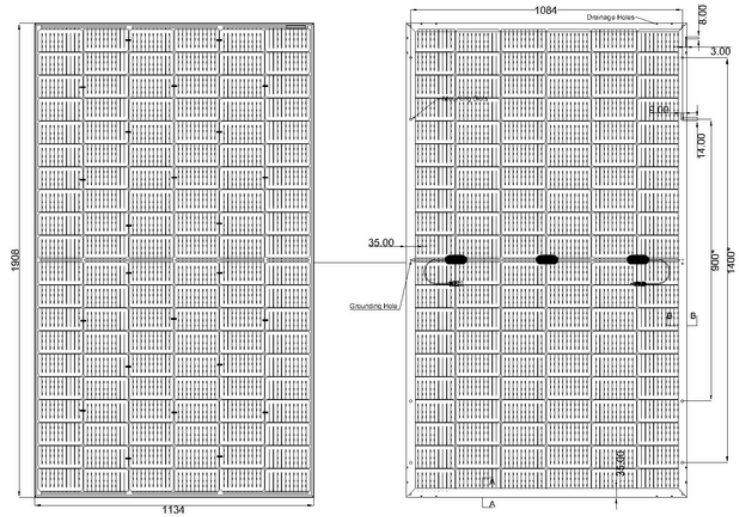
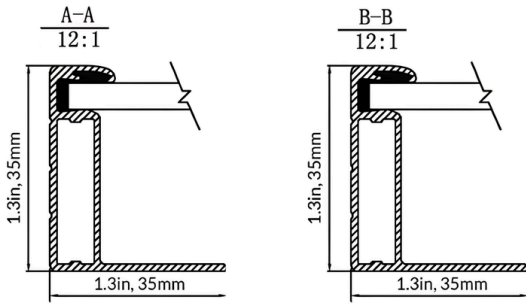

Mechanical Properties	
Cell Type	SE-PERC
Glass	3.2mm(0.12in), anti-reflection coating, high transmission, low iron, tempered glass
Frame	Anodized Aluminum Alloy
Junction Box	IP68
Dimensions	67.7 X 44.6 X 1.3 in, 1722 X 1134 X 35 mm
Weight	51 lbs, 23.13Kg
Output Cable	4mm ² (EU)12AWG
Cable Length	47.2 in, 1200mm
Encapsulant	POE
Connector Type	Staubli EVO2

Electrical Specifications	DNA-120-BF10-445W		DNA-120-BF10-450W		DNA-120-BF10-455W		DNA-120-BF10-460W	
	STC	NOCT	STC	NOCT	STC	NOCT	STC	NOCT
STC Rated Output P _{mpp} (W)	445W	333W	450W	337W	455W	341W	460W	344W
Open Circuit Voltage V _{OC} (V)	41.20	39.32	41.30	39.41	41.50	39.50	41.60	38.92
Short Circuit Current I _{SC} (A)	13.79	11.90	13.86	12.01	13.92	12.12	14.01	12.43
Rated Voltage V _{mpp} (V)	34.00	32.25	34.20	32.32	34.30	32.39	34.43	32.44
Rated Current I _{max} (A)	13.11	10.33	13.20	10.42	13.27	10.51	13.38	10.60
Module Efficiency	20.57%		20.79%		21.03%		21.26%	

Packaging Configuration	
Number of Modules per Pallet	31
Number of Pallets per 40ft. Container	24
Pallet Dimensions	76.29 X 44.48 X 49.76 in, 1938 X 1130 X 1264 mm
Pallet Weight (lbs)	1581lbs, 717.12 Kg
Modules per 40ft. Container	744

Temperature Coefficients	
Temperature Coefficients P _{mpp}	-0.35%/°C
Temperature Coefficients I _{SC}	+0.0453%/°C
Temperature Coefficients V	-0.2738%/°C
Nominal Operating Cell Temperature (NOCT)	45°C±2°C

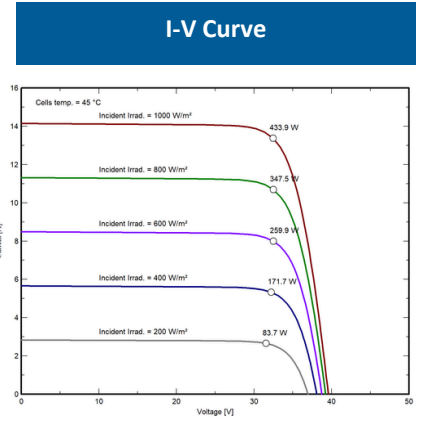

Test Operating Conditions	
Maximum Series Fuse	30A
Maximum System Voltage	1,500 VDC (UL&IEC)
Maximum Load Capacity (Per UL 1703)	5400 Pa Snow Load / 5400 Pa Wind Load**
Fire Performance Type	Type 1

Bifacial Output-Rearside Power Gain				
5%-Maximum Power (Pmax)	467W	473W	478W	483W
5%-Module Efficiency STC(%)	21.60%	21.84%	22.08%	22.32%
15%-Maximum Power (Pmax)	512W	518W	523W	529W
15%-Module Efficiency STC(%)	23.65%	23.92%	24.18%	24.45%
25%-Maximum Power (Pmax)	556W	563W	569W	575W
25%-Module Efficiency STC(%)	25.71%	26.00%	26.29%	26.58%

